



K.SPS XS SAFE TRANSPORT OF 40FT CONTAINERS WITH THE HIGHEST PAYLOAD CAPACITY BY KÄSSBOHRER

Kässbohrer platform semi-trailer, K.SPS XS is engineered to offer the safe transport of 40 ft containers offering highest payload capacity with a tare weight of 5.500 kg, while KTL-coated robust chassis enhances the lifelong performance of the semi-trailer. The ingenious design features container locks at the rear of the trailer, ensuring safety and operational ease during transport of 40ft containers. Reengineered wheelbase guarantees safety and highest maneuverability during transport.

Designed with 20 units of pillar pockets on side rave, 18 units of pillar pockets lined in 4 rows over the platform and 14 units ashing rings with 5 ton capacity each, K.SPS XS offers enhanced load security and operational flexibility. Depending on your payload, K.SPS XS is configured with 30 mm thick hardwood floor and 6 x 2 container locks suitable to carry 1 x 20 ft in the middle, 2 x 20 ft, 1 x 40 ft containers.



K.SPS.XS 3 / 0N - 15 / 27

SPECIFICATIONS

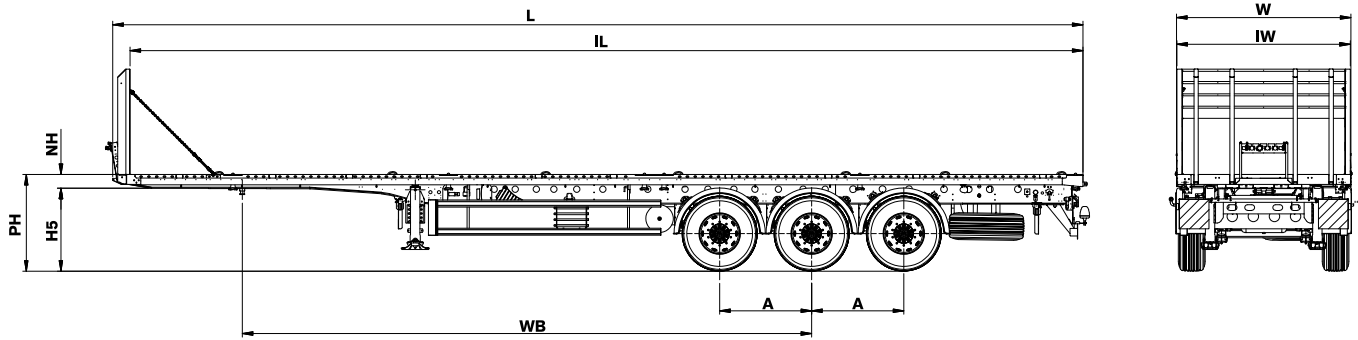

TECHNICAL INFORMATION

Chassis	Made of high quality S700 MC steel in compliance with Standard ISO 1726-2 and ISO 1726; made of two welded longitudinal beams in I form with cross beams at needed distances. Chassis has 2 king-pin position. Reinforced with KTL protection with Kässbohrer expertise (10 years warranty for perforation)
Brake System	Antiblocking (ABS) and rolling control system suitable for UN ECE R13 regulation. EBS 2S / 2M braking system of WABCO brand with electro-pneumatic dual-circuit that contains power supply (RSS) and voltage supply (24N) through brake light
Axles	BPW air suspension and disc brake axle with 9 ton capacity each
Tyre Size	385/65 R22.5
Floor	Hardwood coated, 30 mm thick and water resistant Hardwood flooring that can support 7.200 kg forklift axle load in compliance with DIN EN 283
Container Locks	Equipped with 6 x 2 units of container locks suitable for carrying 1 x 20 ft in the middle, 2 x 20 ft, 1 x 40 ft container. (HC containers are above the permissible height for 1150 mm and higher 5th wheel heights)
K-Fix	K-Fix has holes every 100mm per side rave which increases load lashing varieties. Each load strapping point has a load capacity of 2.500 kg. Additional 7x2 units of lashing rings placed on the floor with a capacity of 5.000 kg.
Front Panel Type	1.500 mm high, removable, high strength steel front panel
Pillars And Pockets	10 x 2 units 83 x 83 mm pillar pockets on side rave +4 rows of 18 units 83 mm x 83 mm pillar pockets on the floor

TECHNICAL DATA

Fifth Wheel Height (H5)	1.180 mm
Gooseneck (NH)	200 mm
Wheelbase (Wb)	8.100 mm
External Length (L)	13.720 mm
Tare Weight ±%3	5.700 kg

TECHNICAL CAPACITIES

King Pin Capacity	15.000 kg
Axle Load	27.000 kg
Total Weight	42.000 kg

Enhanced Features

K-Fix: Load Security System

Multi-point lashing load securing system; coated with cataphoric painting (KTL); 96 x 2 holes on side rail which increases load lashing varieties according to EN 12640

Load Security Systems

7 x 2 units special lashing points with 5-ton capacity in accordance with EN 12640
 10 x 2 units 83 mm x 83 mm pillar pockets on the side rave
 4 rows of 18 units 83 mm x 83 mm pillar pockets on the floor
 1.500 mm KTL coated steel front panel
 6 x 2 units of container locks to carry 1 x 20 ft in the middle, 2 x 20 ft, 1 x 40 ft containers

Certificates

Load Security Certificate EN 12642 Code XL is available with a 1.5 m front panel

Optional Security Systems

20 units of pillars with 1.500 mm height (80 mm x 80 mm)
 800 mm aluminum sideboards with lateral pillars
 Pillar storage on front panel or under the side rave
 2 x 2 units of 423 mm x 423 mm extension warning plates, extendable by 400 mm with 1 unit position lights
 4 x 2 units of ferry rings in compliance with EN 29367-2

Kässbohrer semi-trailers are manufactured according to lean production and quality principles in consideration of total cost of ownership.

Kässbohrer reserves the right to alter the product specification. Visual and technical data subject to change according to vehicle configuration.

Kässbohrer Sales GmbH

Werk Ulm | Im Katzenwinkel 5, 88480 Achstetten, Deutschland | **T** +49 (0) 7392 96797-0 | **F** +49 (0) 7392 96797-67

Werk Goch | Siemensstraße 74, 47574 Deutschland | **T** +49 (0) 2823 9721-0 | **F** +49 (0) 2823 9721-21 | **E** info@kaessbohrer.com | www.kaessbohrer.com