



# K.SKS BS UNIQUE LOAD DISTRIBUTION BY KÄSSBOHRER

Kässbohrer tipper semi-trailer K.SKS B stands for reliability and robustness under the hardest load and road conditions with its high strength chassis and upper structure.

With its unique load distribution performance, K.SKS can carry 26 ton payload with only 9 ton axles, 1 ton more than conventional 2 axle tipper semi-trailers with its standard weight of 5.750 kg. This feature also enhances the service life of axles by distributing the load through king pin. The weight of the vehicle can be brought down to 5.150 kg through weight saving options. The robust chassis with cathophoretic dip coating (KTL) process offers durability and persistence throughout the economic life of the vehicle.

With king-pin capacity of 15.000 kg and unique upper structure design, K.SKS B offers the maximum traction performance on the road and ideal load distribution for road safety. Payload can be increased further by its weight optimized options for 600 kg.

The unique V-shaped form combined with 12 unit bending on the side wall of the upper body increases the acceleration of the load by design providing an easy flowing floor for optimal load discharge. 5 step H-type hydraulic cylinder with a lifting capacity of 250 bar enables fast loading and unloading operations. Engineered to couple with 4 x 2, 6 x 2, 6 x 4 trucks, K.SKS B is equipped with one-touch paving brake system and tilt alert system for operational safety.



# K.SKS B / 27 - 15 / 18

## SPECIFICATIONS

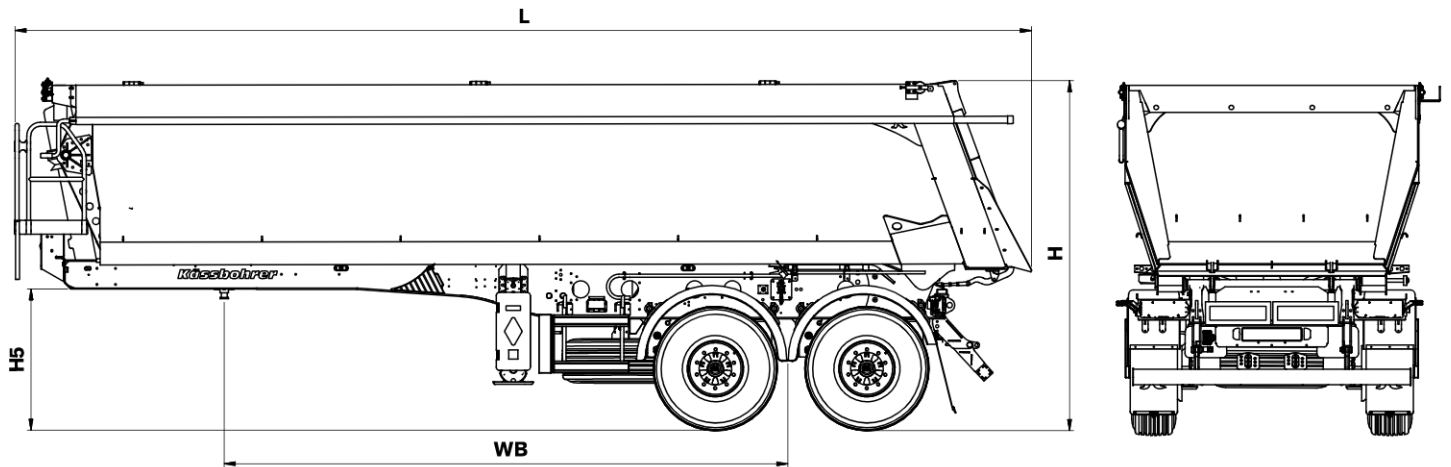

### TECNICAL INFORMATION

<b>Chassis</b>	Made of high quality and strength S700 MC steel, in compliance with Standard ISO 1726-2 and ISO 1726; made of two welded longitudinal beams in "I" form with cross beams at needed distances. Reinforced with KTL protection with Kässbohrer expertise (10 years warranty for perforation)
<b>Brake System</b>	Dual circuit electro-pneumatic WABCO brand EBS 2S/2M brake system with anti-lock (ABS) and tilt control system (RSS) in compliance with Regulation UN ECE R13
<b>Electric System</b>	Aspöck Europoint III lightning installation with 24V LED side position lamp and 2 x 7 and 1 x 15 pin sockets, in compliance with Regulation UN ECE R48 and ADR Legislation
<b>Axles</b>	BPW AL II HD air suspension and disc brake axle with 9 ton capacity each
<b>Body</b>	The front wall, door and side wall are made of and the floor is made of HB450 high strength and wear- and impact resistant steel
<b>Hydraulic System</b>	5-step* cylinder with a lifting capacity of 250 bar and 1m long, 1" diameter hydraulic hose connection which is suitable for male and female connection are included. (*5-step HYVA for 24, 27 and 32 m3 DE and 32 m3 RU vehicles)

### TECNICAL DATA

<b>Fifth Wheel Height (H5)</b>	1.220 mm
<b>Wheelbase (WB)</b>	4.900 mm
<b>External Length (L)</b>	9.030 mm
<b>Total Width (W)</b>	2.550 mm
<b>Tare Weight ±%3</b>	5.950 kg
<b>Volume</b>	27,0 m3

### TECNICAL CAPACITIES

<b>Axle Load</b>	18.000 kg
<b>King Pin Capacity</b>	15.000 kg
<b>Gross Weight</b>	33.000 kg

### ENHANCED FEATURES

- Maximum payload:** Unique upperbody design and positioning allows 1 ton extra material loading.
- Body-Fix:** Rattling absorbers mounted on the chassis to prevent any possible noise pollution during discharge
- Tipping shaft:** Wide tipping shaft provides better stability during your tipping operation by distributing the load to a wider area
- Tilt alert:** An audible alarm signal and a light indicator, allowing the driver to lower the tipper in time to prevent a roll over
- Unloading level:** Air bag pressure release system, lowering the platform height for safe discharge operation
- Finisher brake system:** Equipped with a switch for controlling automatic braking system, suitable for asphaltting machinery
- Safety brake function:** Automatic braking system, preventing any movement during the unloading process
- Rolling tarpaulin:** Mechanical rolling pipe tarpaulin mounted to side walls
- e-TASC:** Electronic trailer air suspension control
- Smartboard:** Allowing to operate and display EBS E and and suspension functions

### Wide Range of Options

- Hydraulic rear wall with remote control
- Electrical / manual sliding tarpaulin
- Pneumatic folding rear bumper
- Wall & floor thickness options
- Self steering 3rd axle
- Disc / Drum brakes
- Grain door
- Sealing rubber at rear door
- Tightening rear door locks
- Quick coupling connection
- Aluminum air tanks
- Aluminum mechanical legs
- Aluminum rims
- Fire extinguisher box
- Plastic toolbox
- Aluminum ladder
- Spare wheel and holder

**Kässbohrer semi-trailers are manufactured according to lean production and quality principles in consideration of total cost of ownership.**

*Kässbohrer reserves the right to alter the product specification. Visual and technical data subject to change according to vehicle configuration.*

**Kässbohrer Sales GmbH**

**Werk Ulm** | Im Katzenwinkel 5, 88480 Achstetten, Deutschland | T +49 (0) 7392 96797-0 | F +49 (0) 7392 96797-67

**Werk Goch** | Siemensstraße 74, 47574 Deutschland | T +49 (0) 2823 9721-0 | F +49 (0) 2823 9721-21 | E info@kaessbohrer.com | [www.kaessbohrer.com](http://www.kaessbohrer.com)