



# K.SSL 38 EFFICIENCY IN OPERATIONS & MEETING SPECIFIC NEEDS BY KÄSSBOHRER

Kässbohrer offers the optimum payload capacity with its 38 m<sup>3</sup> non-tipping silo K.SSL 38, for the most efficient and transportation and fast discharge of dry bulk materials. With Kässbohrer's quality and performance proven box profile chassis, K.SSL 38 features safe lateral inclination, and lower center of gravity which results in high maneuverability even in the toughest working conditions.

K.SSL 38 is designed with precise cone angles and electro polished tank walls for fast unloading of bulk materials. With options such as separation wall in the tanker, different number of filling domes, pneumatic filling necks, various aeration cone types, freefall butterfly valve, ringduse and air compressor K.SSL 38 meets the specific operational needs of its customers and providing efficiency in operations. Depending on the on-site working conditions, K.SSL 38 is offered with several discharge options such as individual discharging per cone at left or right, single discharging at both sides or discharge from the rear side.



# K.SSL 38 / 2 - 10 / 24

## SPECIFICATIONS

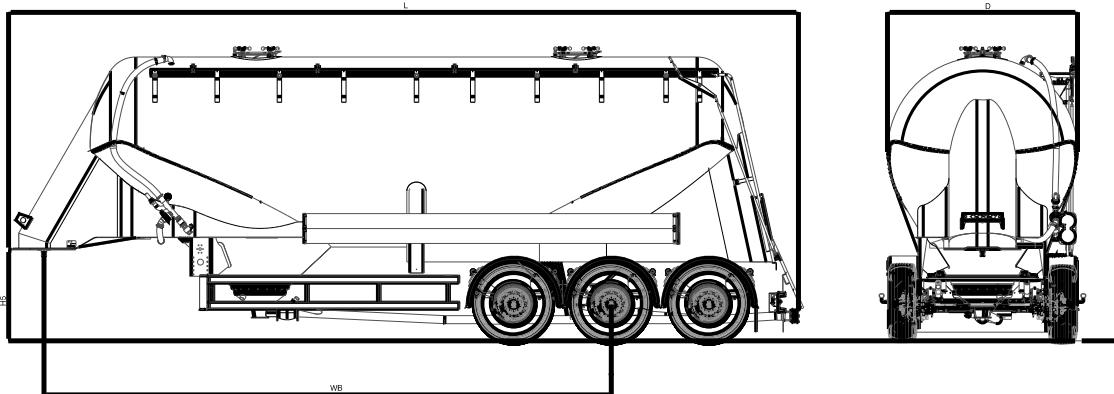

### TECHNICAL INFORMATION

<b>Chassis Type</b>	Aluminum extrusion profile frame, welded inside the support console (Welded Construction)
<b>Brake System</b>	There is a dual-circuit electro-pneumatic braking system with EBS 2S / 2M antiblocking system suitable for UN ECE R13
<b>Axle Brand</b>	Equipped with BPW branded 3 air suspension axles with 9 ton permissible load capacity each
<b>Electric System</b>	ASPÖCK lightning installation with 24 V LED side position lamp and 2x7 and 1x15-pin sockets, in compliance with Regulation UN ECE R48 and ADR Legislation
<b>Tyre Size</b>	Tyre size 385/65 R 22.5
<b>Number Of Compartments</b>	1 Compartment
<b>Manhole Number</b>	3 x DN450 Pressure Type Domes
<b>Discharge Type</b>	Discharge type from the rear
<b>Hose Carrier</b>	2 x NW100, 5 M hose holder with rear cover

### TECHNICAL DATA

<b>Fifth Wheel Height (H5)</b>	1.220 mm
<b>Tank Diameter (D)</b>	2.550 mm
<b>Wheelbase (Wb)</b>	7.615 mm
<b>External Length (L)</b>	10.605 mm
<b>Volume</b>	38,0 m <sup>3</sup>
<b>Tare Weight ±%3</b>	4.978 kg
<b>Operation Temperature °C</b>	-20/80°C
<b>Test Pressure (Bar)</b>	3,0 bar
<b>Operation Pressure (Bar)</b>	2,0 bar

### TECHNICAL CAPACITIES

<b>Total Weight</b>	39.000 kg
<b>King Pin Capacity</b>	12.000 kg
<b>Axle Load</b>	27.000 kg

### Enhanced Features

#### Volume Options

Depending on the density of the material that will be transported, the silo can be manufactured with different volumes such as; 31 m<sup>3</sup>, 35 m<sup>3</sup>, 38 m<sup>3</sup>, 40 m<sup>3</sup> and 45 m<sup>3</sup>

#### Certification

Pressure Equipment Directive 2014-68 EC approved design Compliant with ECTA / DOW best practices

#### Discharge Solutions

According to the on-site working conditions of the silo, discharge line and port can be:

Individual discharging per cone at left or right

Single discharging at left or right

Discharge line under or inside the chassis when discharging at rear

#### Wide Range of Options

Additional compartment and filling domes

Pneumatically operated folding handrail with options of stainless steel or aluminum

Various additional options such as compressor with diesel or electrical engine

Vibrator, cleaning gun, compressor hose carrier, toolboxes and custom lock / TIR cable

Brake Lock System, IVTM, Pad wear, PSI systems and other additional equipments

Different size of hose and hose carriers

Bolted Cone Design

Coupling Types

**Kässbohrer semi-trailers are manufactured according to lean production and quality principles in consideration of total cost of ownership.**

*Kässbohrer reserves the right to alter the product specification. Visual and technical data subject to change according to vehicle configuration.*

**Kässbohrer Sales GmbH**

**Werk Ulm** | Im Katzenwinkel 5, 88480 Achstetten, Deutschland | **T** +49 (0) 7392 96797-0 | **F** +49 (0) 7392 96797-67

**Werk Goch** | Siemensstraße 74, 47574 Deutschland | **T** +49 (0) 2823 9721-0 | **F** +49 (0) 2823 9721-21 | **E** info@kaessbohrer.com | [www.kaessbohrer.com](http://www.kaessbohrer.com)